

VRESI 120 MSC
VRESI 120 MSC IP65
VRESI 160 MSC
VRESI 160 MSC IP65
VRESI ANT MSC
VRESI ANT MSC IP65
VRESI ESC MSC
VRESI ESC MSC IP65



EN Information on the Change of Battery

If the backup does not extend to the declared duration, the battery has to be replaced. The electric source for safety service is not a user serviceable item and shall only be replaced by the manufacturer service agent or a similar qualified person.

DE Information zum Akku-Tausch

Erreicht die Notstromversorgung nicht die angegebene Dauer, muss die Batterie ausgetauscht werden. Die Stromquelle für Sicherheitszwecke ist kein vom Anwender zu wartender Gegenstand und darf nur von einem Kundendienstmitarbeiter des Herstellers oder einer ähnlich qualifizierten Person ersetzt werden.

FR Informations sur l'échange de la batterie

Si la sauvegarde ne se prolonge pas jusqu'à la durée déclarée, la batterie doit être remplacée. La source électrique du service de sécurité n'est pas un élément réparable par l'utilisateur et ne doit être remplacée que par l'agent de service du fabricant ou une personne qualifiée similaire.

IT Informazioni sulla sostituzione della batteria

Se il backup non raggiunge la durata dichiarata, la batteria deve essere sostituita. La sorgente elettrica per il servizio di sicurezza non è un elemento riparabile dall'utente e deve essere sostituita solo dall'agente di assistenza del produttore o da una persona qualificata simile.

ES Información sobre la sustitución de la batería

Si la reserva no alcanza la duración declarada, deberá sustituirse la batería. La fuente eléctrica para el servicio de seguridad no es un elemento reparable por el usuario y sólo debe ser sustituido por el agente de servicio del fabricante o una persona cualificada similar.

NL Informatie over vervanging van de batterij

Als de back-up niet de aangegeven duur bereikt, moet de batterij worden vervangen. De elektrische bron voor de veiligheidsdienst kan niet door de gebruiker worden onderhouden en mag alleen worden vervangen door de serviceagent van de fabrikant of een vergelijkbaar gekwalificeerd persoon.

SV Information om utbyte av batteri

Om backupen inte räcker till den angivna tiden måste batteriet bytas ut. Den elektriska källan för säkerhetsservicen kan inte servas av användaren och får endast bytas ut av tillverkarens serviceombud eller liknande kvalificerad person.

FI Tietoa akun vaihtamisesta

Jos varmuuskopiointi ei kestä ilmoitettua aikaa, akku on vaihdettava. Turvallisuuspalvelun sähkölähde ei ole käyttäjän huollettavissa oleva osa, ja sen saa vaihtaa vain valmistajan huoltoliike tai vastaava pätevä henkilö.

RU Информация о замене батареи

Если время резервного копирования не соответствует заявленному, необходимо заменить батарею. Источник электрический источник для службы безопасности не является предметом обслуживания пользователя и должен заменяться только сервисным агентом производителя или аналогичным квалифицированным специалистом.

PL Informacje dotyczące wymiany baterii

Jesli podtrzymanie nie trwa przez zadeklarowany czas, nalezy wymienic baterie. Elektryczne źródło bezpieczeństwa nie jest elementem serwisowanym przez użytkownika i może być wymieniane wyłącznie przez przedstawiciela serwisowego producenta lub podobną wykwalifikowaną osobę.



**CAUTION: Lithium batteries included!
OBSERVE Manufacturer's Safety Instructions!**

Do not tamper with the rechargeable batteries and/or battery packs in any way!
In principle, it can be assumed that lithium batteries are comparatively safe when handled properly.

SAFETY DATA SHEET

TRIDONIC (EN)

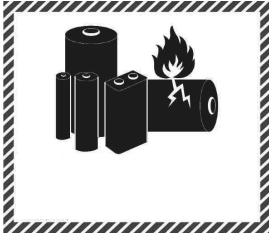

Possible hazards:

Lithium batteries or lithium accumulators contain:

- Lithium or its compound (reacts violently)
- Flammable organic solvents
- Oxidising agents (fire promoters)
- Reactive halogen compounds

i Additional battery information



TRIDONIC (EN)



TRIDONIC (DE)

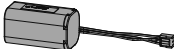

i Exchange batteries

Luminaire		Spare battery	
	Driver Type	Order code	Name
VRESI 120/160	E3; E3T; E3D, E3BC	59014795	"ACCU_LIION 3.2V 1.5Ah 18650 1 STI #VRESI 
VRESI ANT/ANT HC	E3T; E3DP; E3BCP	59014796	"ACCU_LIION 3.2V 3Ah 18650 2 SBS #VRESI 
VRESI ESC/ESC HC	E3T; E3DP; E3BCP		
VRESI ANT/ANT HC HP	E1T; E3T; E3DP; E3BCP	59014797	"ACCU_LIION 3.2V 6Ah 18650 4 SBS #VRESI 
VRESI ESC/ESC HC HP	E1T; E3T; E3DP; E3BCP		

1 

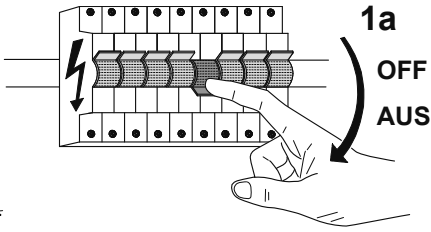

1b 

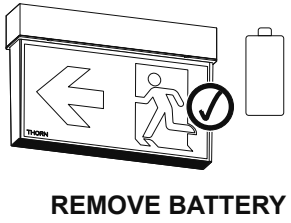
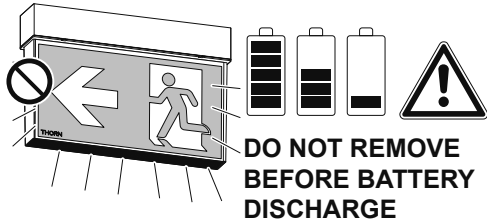

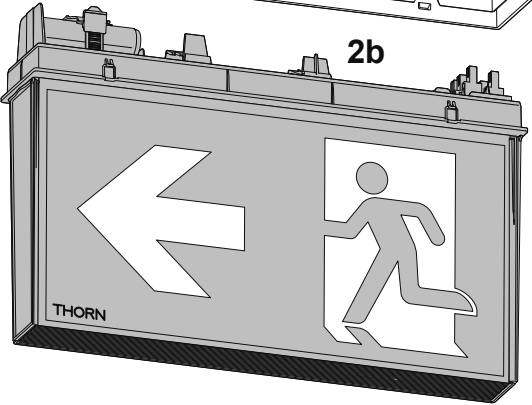
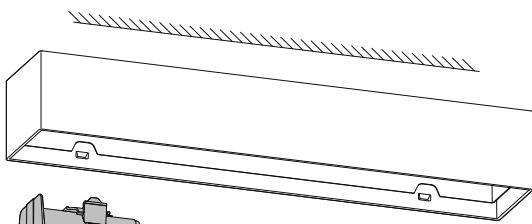
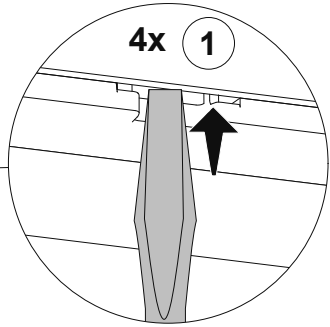
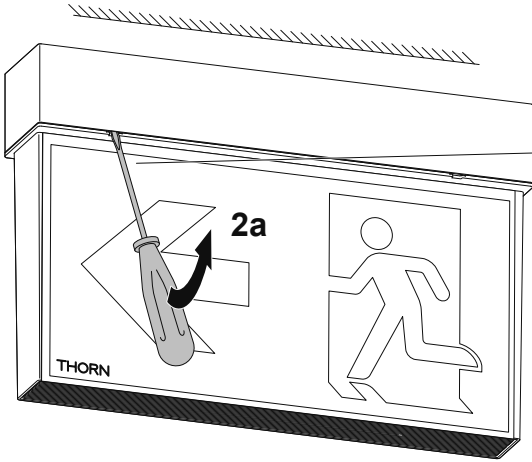

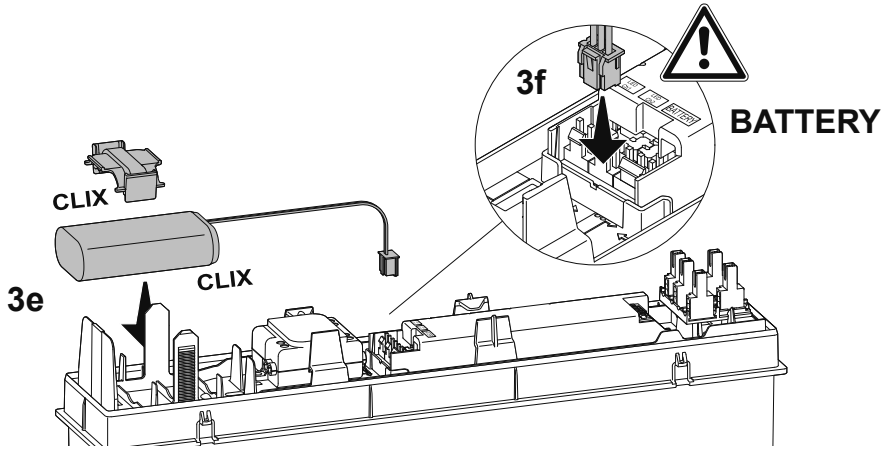
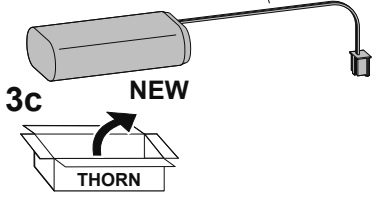
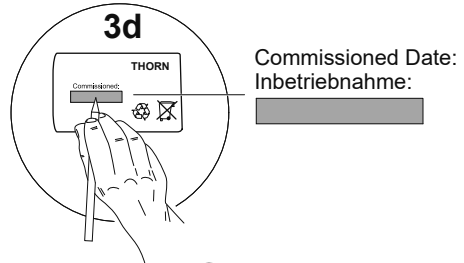
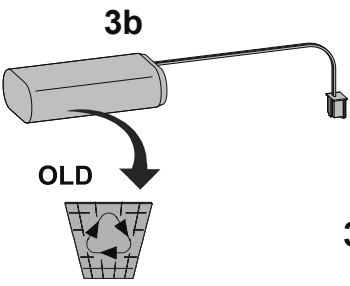
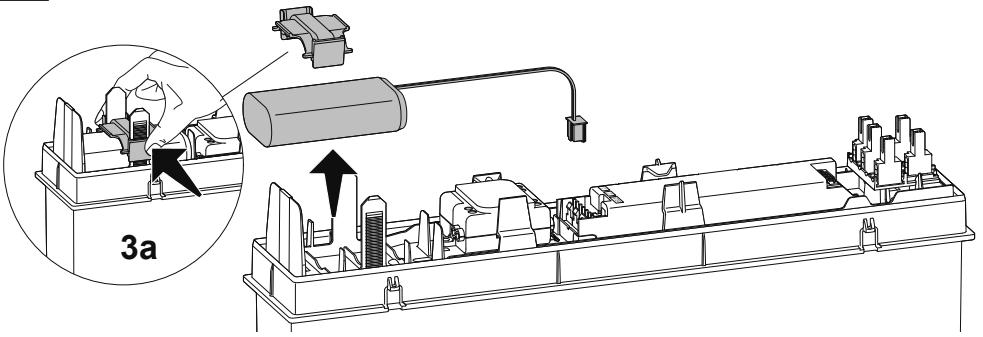

4

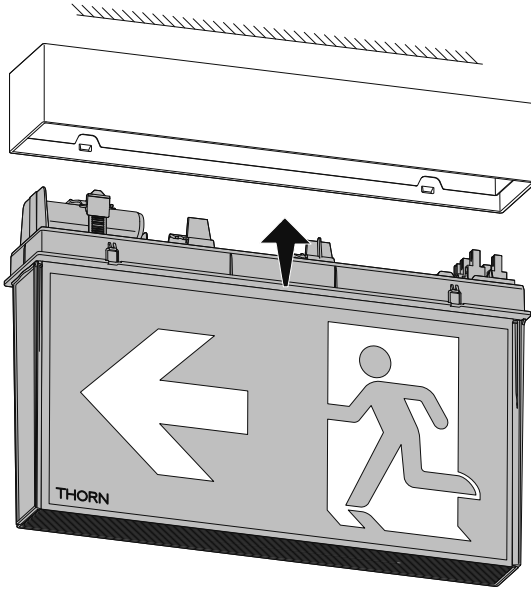

5

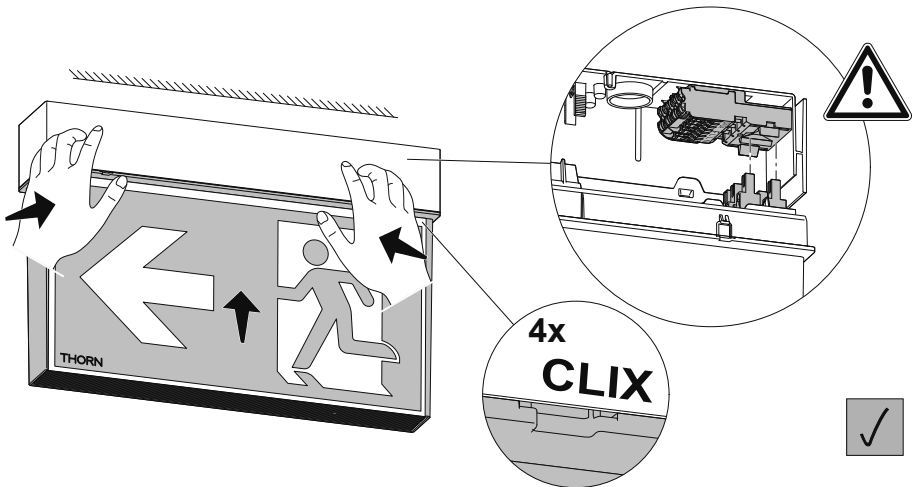

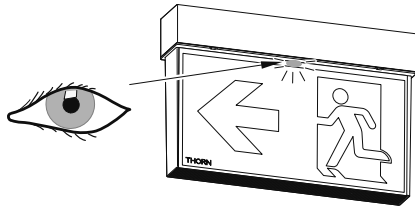
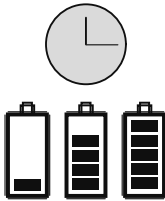
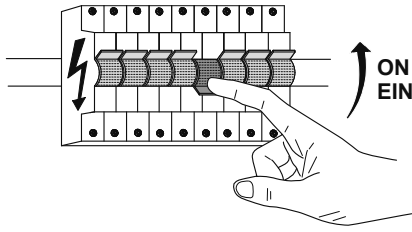

i ExT, ExD, ExBC Status LED

LED GREEN / GRÜN

Status

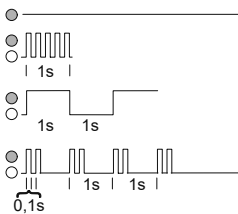

Everything okay
Alles o. k.
Function test
Funktionstest
Service life test
Betriebsdauertest
Disabled
Blockiert

LED RED / ROT

Status

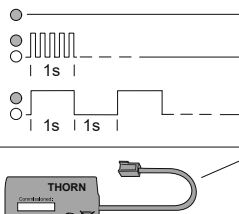

Lamp failure
Lampenfehler
Charging failure
Ladefehler
Battery failure
Batteriefehler

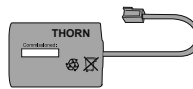

Change battery
Akku wechseln

